

Mist Separator (SAFM) Micro Mist Separator (SAFD)

SAFM200~400 Series
SAFD200~400 Series



SAFM200



SAFD200

- Series SAFM Nominal filtration rating: 0.1 μm.
- Series SAFD Nominal filtration rating: 0.01 μm.

How to order

SAFM 3 00 - 03 BD - MeP
Mist Separator

SAFD 3 00 - 03 BD - MeP
Micro Mist Separator

① Body Size

- 2 - 1/4
- 3 - 3/8
- 4 - 1/2, 3/4

② Thread type

- Nil - Rc(PT)
- N - NPT
- G - G(PF)

③ Port Size

Symbol	Size	Body size		
		2	3	4
02	1/4	●		
03	3/8		●	
04	1/2			●
06	3/4			●

④ Accessory(Optional)

- Nil - None Bracket / Manual Drain
- B - Bracket
- D - Auto Drain

Symbol	Description	Body		
		2	3	4
D	One-touch fitting type	●	●	●
Dn	Nipple(PT1/8) type	-	●	●
Df	SAFM, SAFD200 Float type	●	-	-

주) 1. SAFM, SAFD200 are differential pressure type.
2. SAFM, SAFD300~400 are float type.

⑤ Bowl

- Nil - PC bowl
- MeP - Metal bowl with pipe type sight glass

Symbol

SAFM
SAFD

오토드레인부착 SAFM
오토드레인부착 SAFD

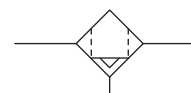
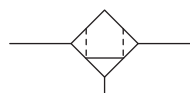

Specification

Fluid	Compressed Air	
Max. operating pressure	10bar (1.0MPa)	
Min. operating pressure	0.5bar (0.05MPa)	
Max. supply pressure	15bar (1.5MPa)	
Ambient and Media temp.	-5 ~ 60°C (No freezing)	
Filtration	SAFM	0.1μm
	SAFD	0.01μm
Construction	Poly-carbonate (option: ALDC)	

Precautions

- Do not use Poly-carbonate bowls in an environment where they are exposed to or come in contact with organic solvents, chemicals, cutting oil, synthetic oil, alkali, and thread lock solutions.
- Components with a bowl must be installed vertically with the bowl downward so that faulty drain discharge and dripping can be verified.
- When auto drain is used, drain piping should be both 4mm or greater in diameter and less than 1m in length. Avoid installing drain piping upwards.
- When auto drain is used it is recommended to use at least 1.5bar pressure.
- When auto drain is inoperable, drain manually by pushing the one-touch fitting upward.
- Before disassembling the equipment on the compressed air side to inspect the auto drain or to replace the filter element, confirm that the pressure is set to zero.

Mist Separator Micro Mist Separator

■ FLOW CHARACTERISTICS

(— Element oil saturation - - - - Initial condition)

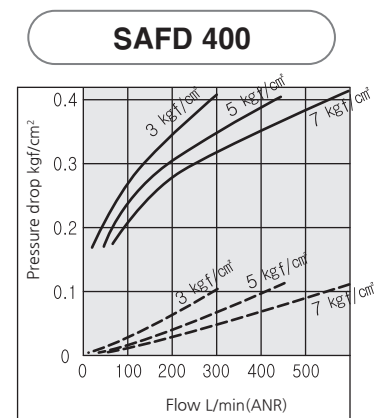
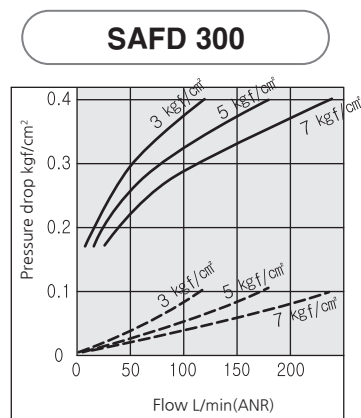
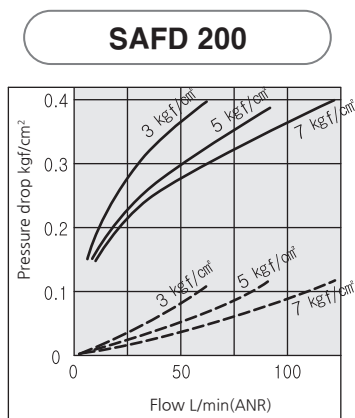
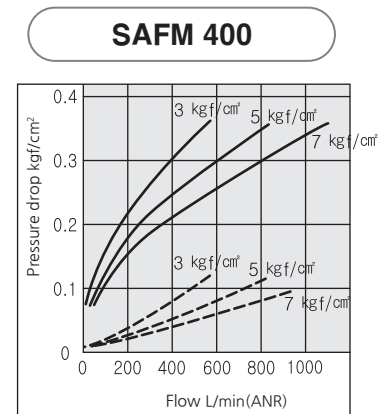
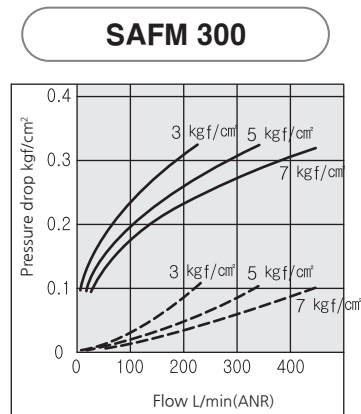
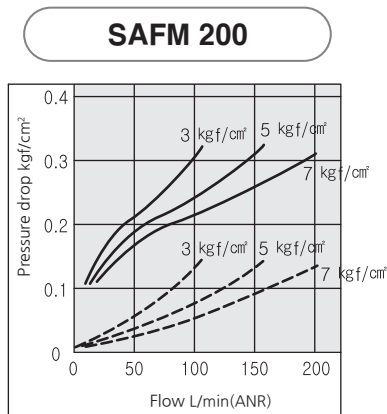

■ STRUCTURE / PARTS

**SAFM 200
SAFD 200**

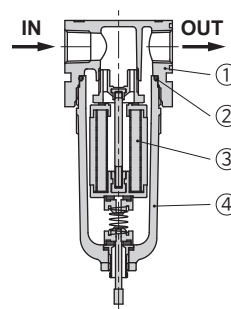

**SAFM 300 to 400
SAFD 300 to 400**

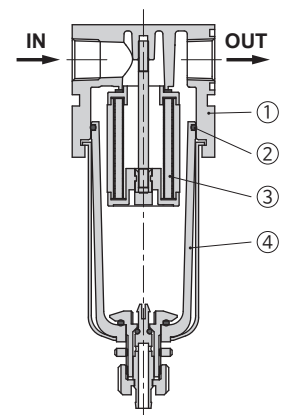

■ Component Parts

No.	PARTS	MATERIAL
①	Body	ALDC
④	Bowl Ass'y ¹⁾	PC

Note : 1. Bowl Ass'y comes with a bowl guard (steel band material).

■ Replacement Parts

No.	PARTS	MATERIAL	Part no.					
			SAFM200	SAFD200	SAFM300	SAFD300	SAFM400	SAFD400
②	O-ring	NBR	U024		38x2		U137	
③	Filter	-	FM200-EL	FD200-EL	FM300-EL	FD300-EL	FM400-EL	FD400-EL

SAU

SAU
LARGE FLOW

SAU
HIGH PRESS.

SAW

SAWM
SAWD

SAF

SAF
LARGE FLOW

SAFM
SAFD

SAR

SAR
LARGE FLOW

SAR
T-HANDLE

SAR
HIGH PRESS.

SRP

SAL

SAL
LARGE FLOW

AUTO-DRAIN
KITS

SHVS

SPS100

ACCESSORY

CAUTION

Series SAFM200~400
Series SAFD200~400

■ DIMENSIONS (mm)

SAFM(SAFD) 200

■ SAFM(SAFD) 200-□02□□

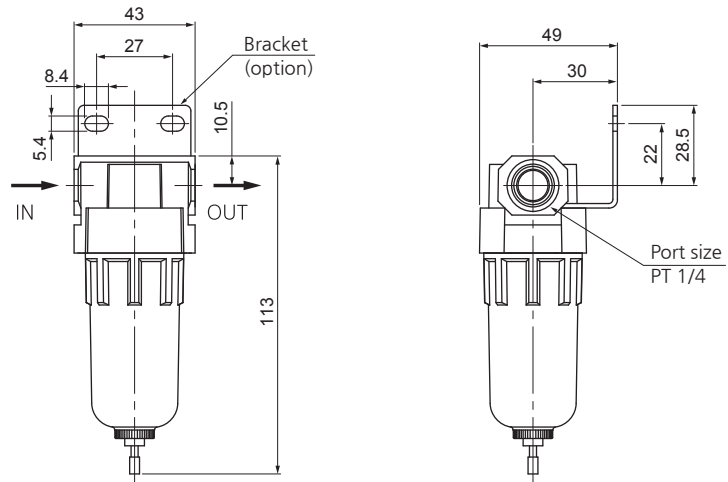

■ Dimensions of each model with an option attached

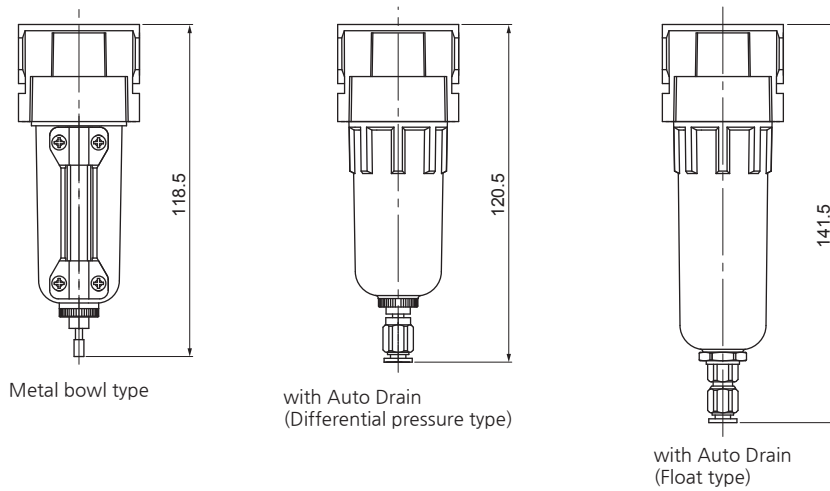

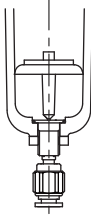
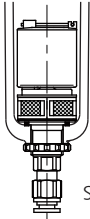
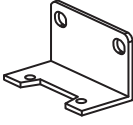
Option	Auto Drain		B : Bracket
	D : Differential pressure type	Df : Float type	
Model		 SAD200	 B200

Mist Separator Micro Mist Separator

■ DIMENSIONS (mm)

SAFM(SAFD) 300

- SAFM(SAFD)300-□03□□

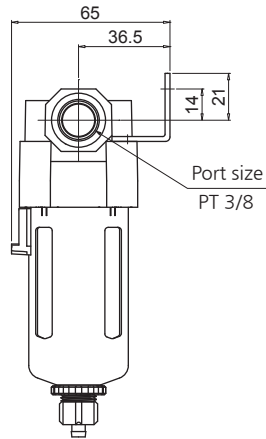
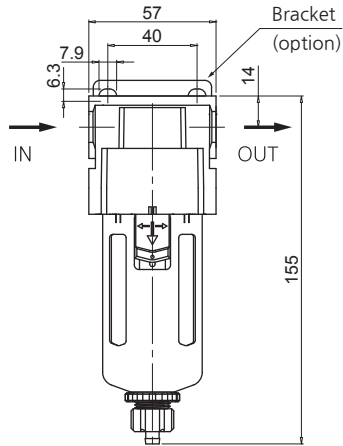

- Dimensions of each model with an option attached

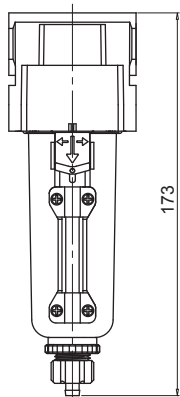

Metal bowl type

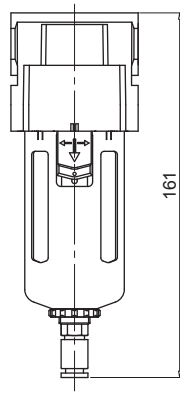

with Auto drain

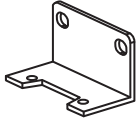
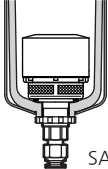
Option	B : Bracket	D : Auto Drain
Model	 B300	 SAD300

- SAU
- SAU
LARGE FLOW
- SAU
HIGH PRESS.
- SAW
- SAWM
SAWD
- SAF
- SAF
LARGE FLOW
- SAFM
SAFD**
- SAR
- SAR
LARGE FLOW
- SAR
T-HANDLE
- SAR
HIGH PRESS.
- SRP
- SAL
- SAL
LARGE FLOW
- AUTO-DRAIN
KITS
- SHVS
- SPS100
- ACCESSORY
- CAUTION

Series SAFM200~400
Series SAFD200~400

■ DIMENSIONS (mm)

SAFM(SAFD) 400

- SAFM(SAFD)400-□04□□
SAFM(SAFD)400-□06□□

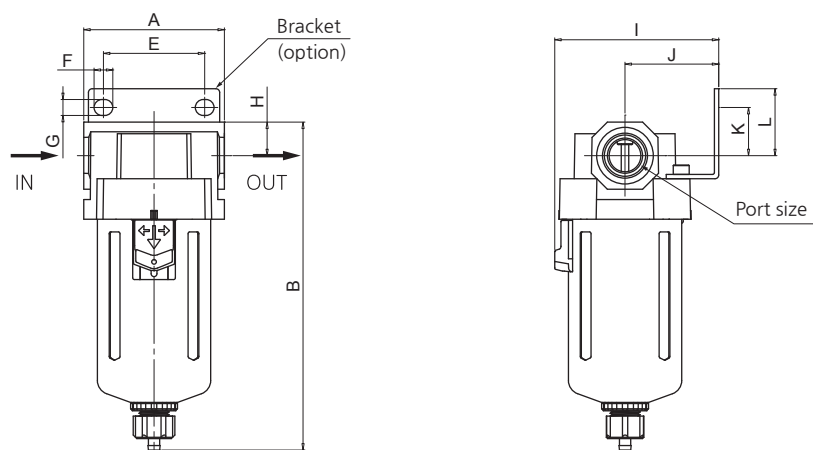

- Dimensions of each model with an option attached

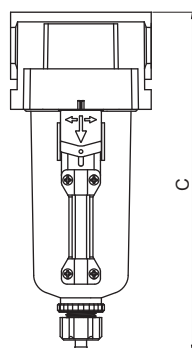

Metal bowl type

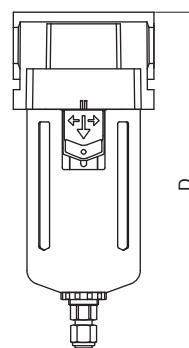

with Auto drain

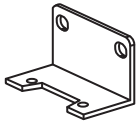
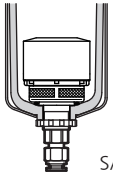
Option	B : Bracket	D : Auto Drain
Model	 B400	 SAD400

Model	Port size	A	B	C	D	E	F	G	H	I	J	K	L
SAFM(SAFD)400-04	1/2	75	174	179	181	54	10	8.5	17.9	85	50	25.7	35.7
SAFM(SAFD)400-06	3/4	75	178	183	185	54	10	8.5	19.8	85	50	25.1	35.1